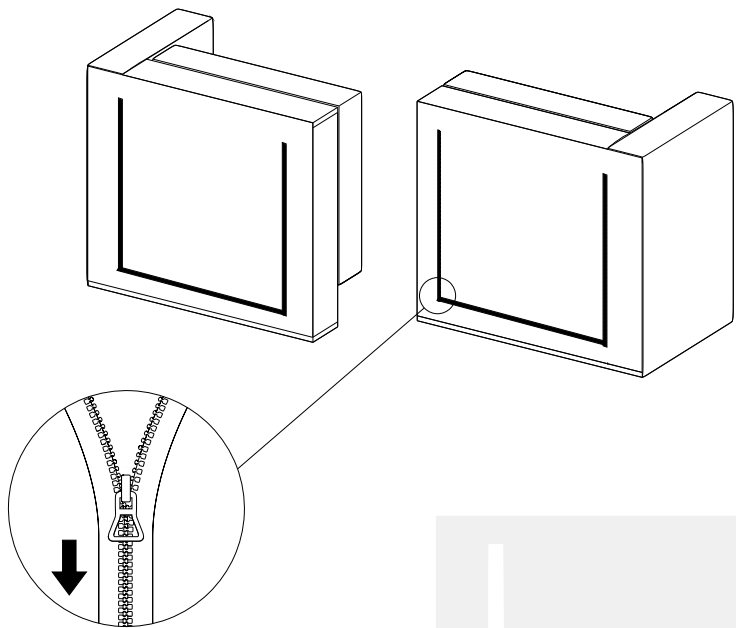
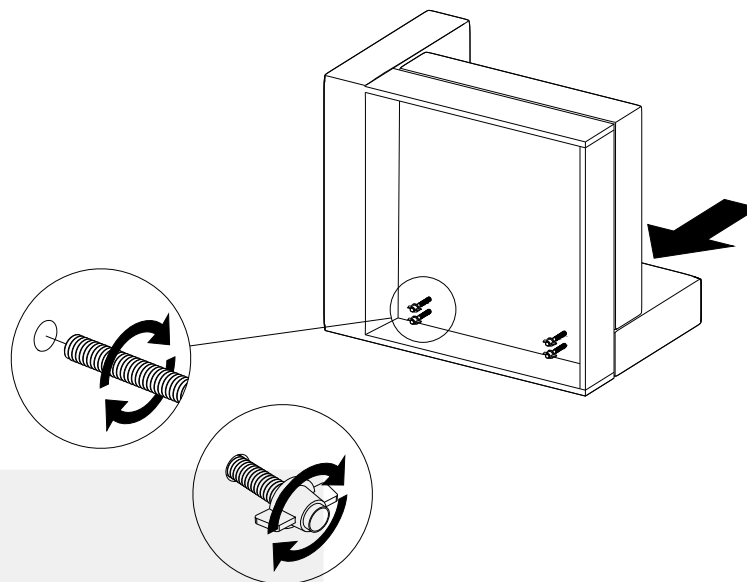

**STEP-1**

- Tilt the sofas on their backside.
- Open the zippers under the sofas.

**STEP-2**

- Place the back sofa onto the seats arms from overhead.

**STEP-3**

- Fix the legs(3) to the base holes & arms.

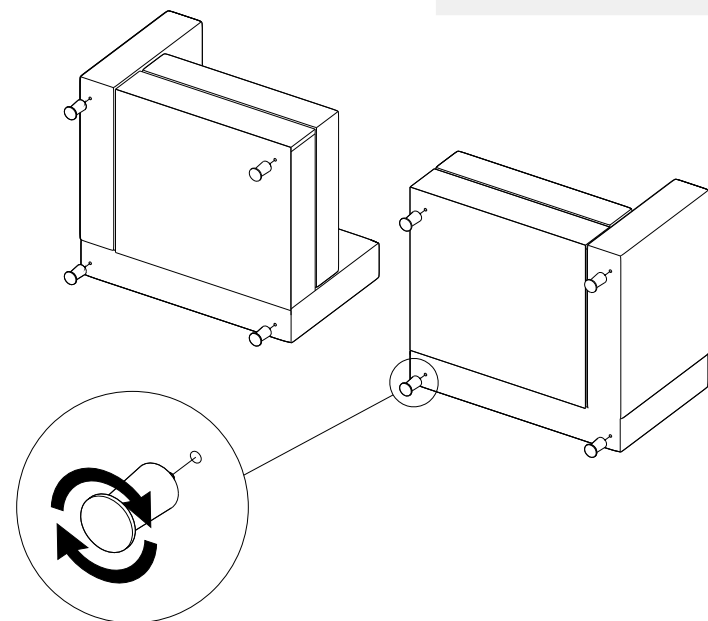
**STEP-4**

- Assemble the seats with the help of connection apparatus.

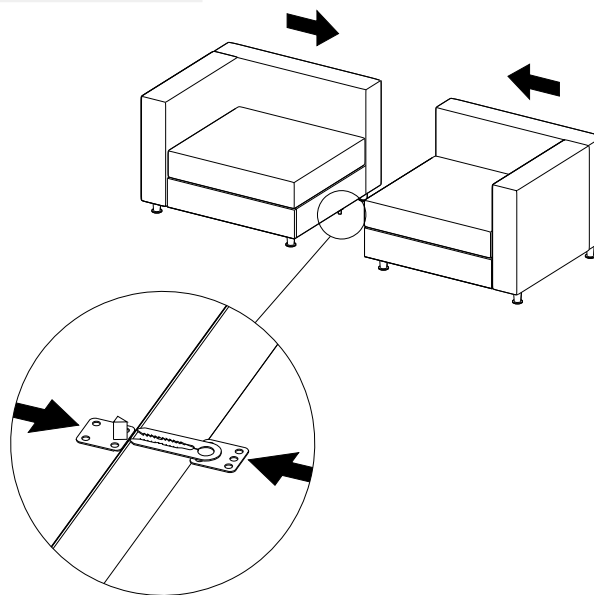

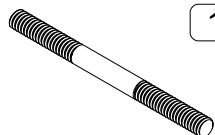
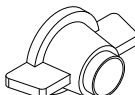
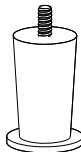
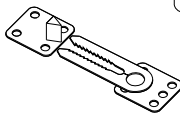
 <p>1</p> <p>CONNECTION APPARATUS (x 8)</p>	 <p>2</p> <p>WING NUT (x 8)</p>
 <p>3</p> <p>LEG (x 8)</p>	 <p>4</p> <p>CONNECTION APPARATUS (x 1)</p>